

DWG STATUS					ZONE	REVISION HISTORY			AUTH	DR	APVD1	APVD2
DATE	STG	REV	N/P	CHG								
16JL19	R	01	-	-		WAS PE443439			444791	LG	AYZ	TY

HV 2WAY SPECIAL
3 SCREW HOLES

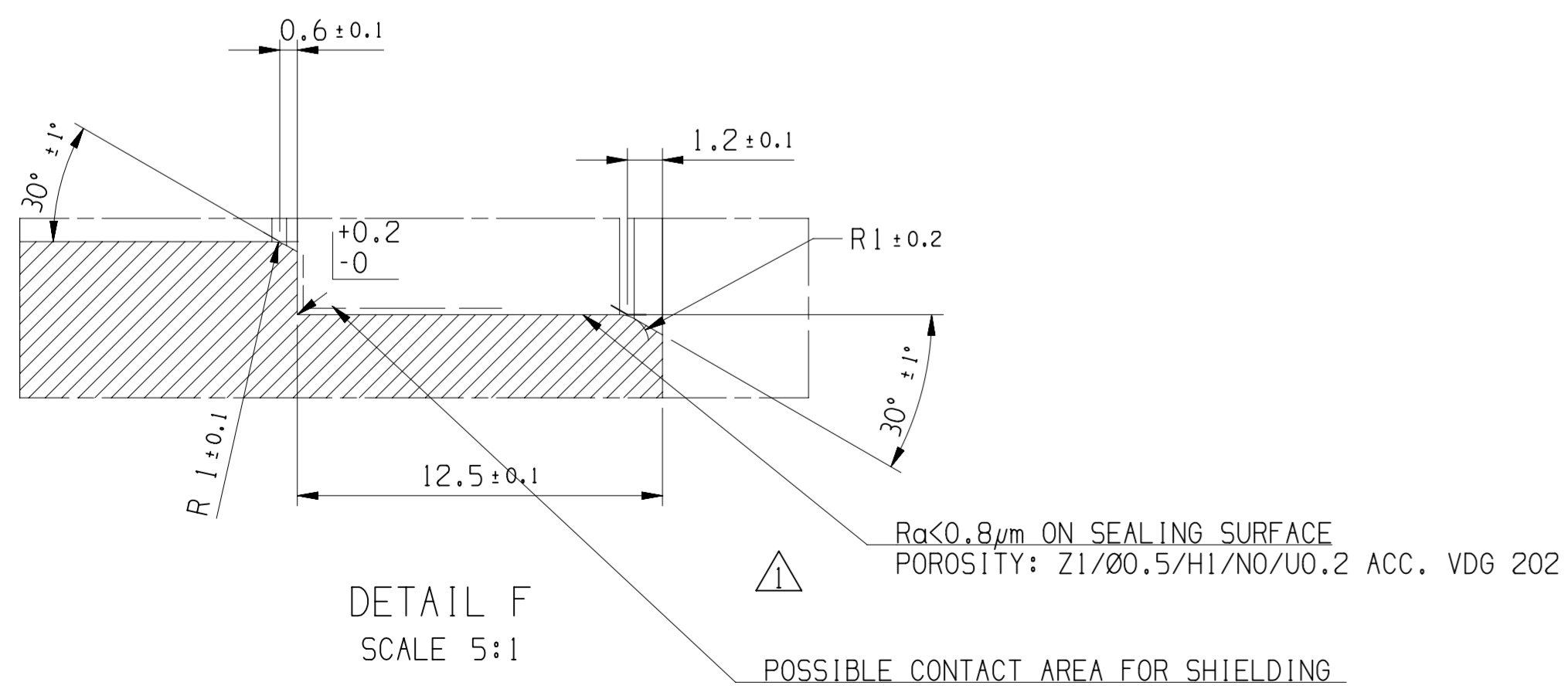
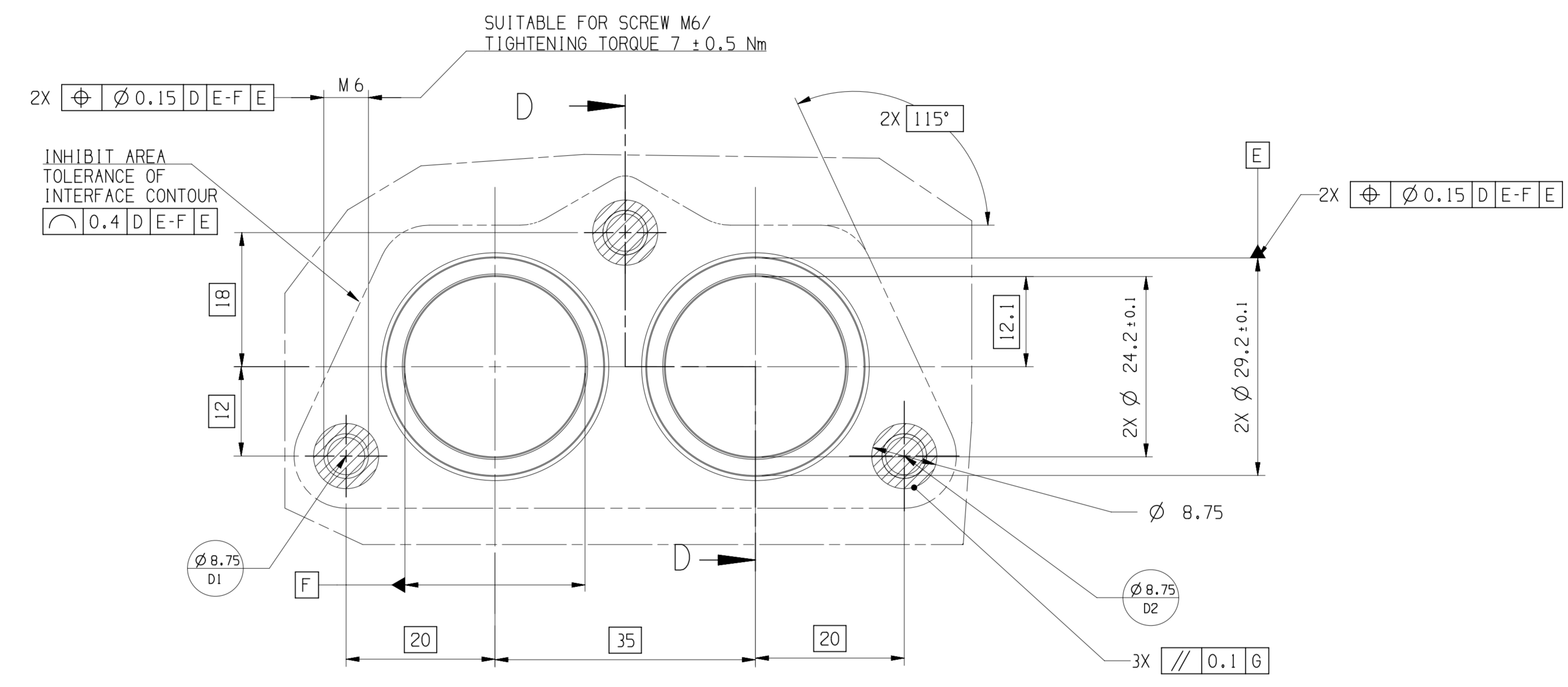
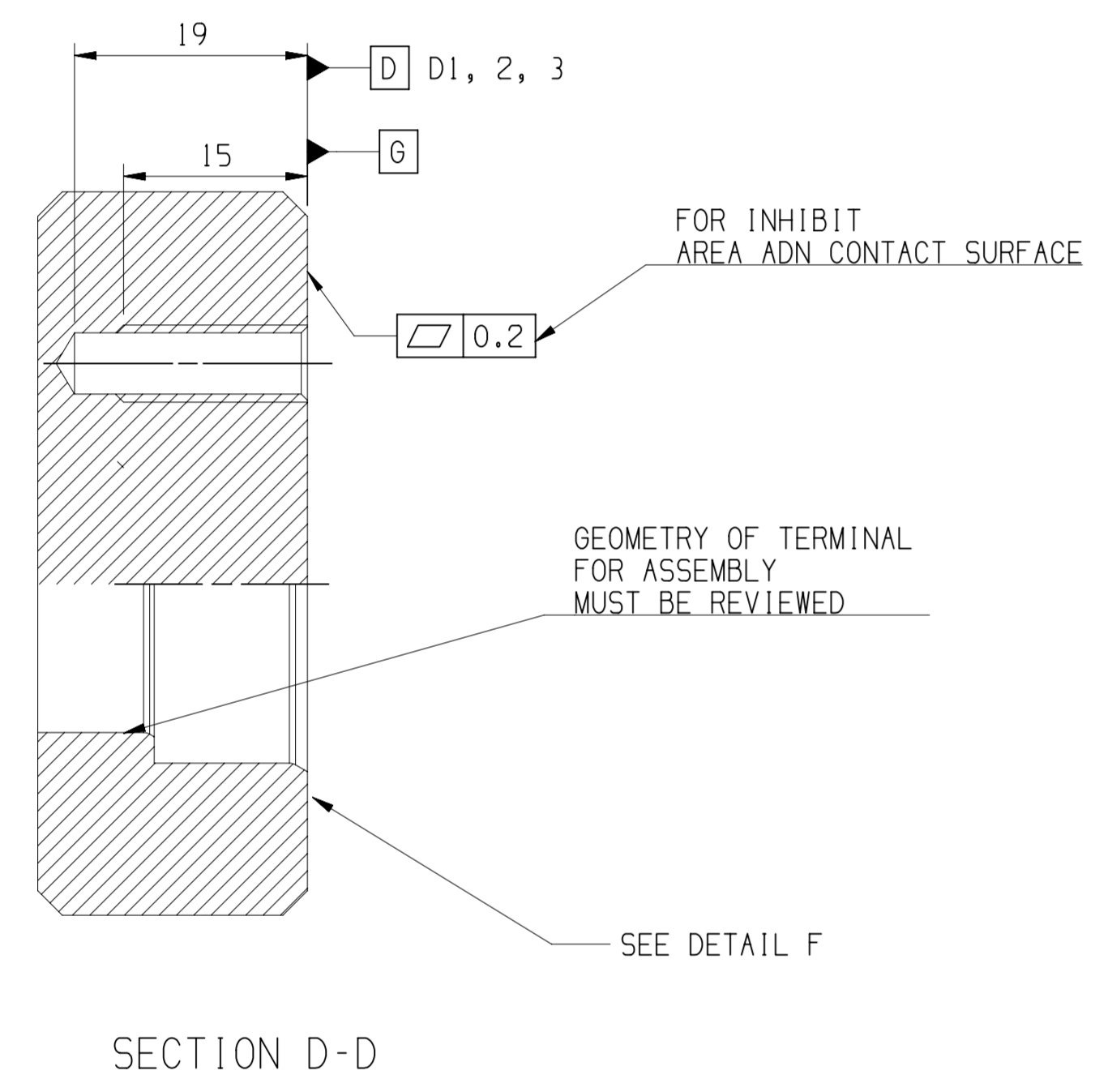

- NOTES:
- REFERENCE PLANE CORRELATES TO THE UNREELD GIRTHED SURFACE OF THE DRILLED HOLE IN THE SEALED AREA
 - REQUIREMENT (EMC, SHIELD CONTACT RESISTANCE, ETC.) TO BE MET ACC. TO 35219981-CUS74-S01.
 - NON-SPECIFIED RADII MAX. R=0.5MM
 - ALL SYMMETRIC DIMENSIONS $\pm 0.1 \text{ (M)}$
 - MINIMUM CLEARANCE AND CREAPAGE DISTANCES MUST BE CHOSEN ACC. TO DIN EN 60664-1.01/2008, AND IS IN THE RESPONSIBILITY OF THE USER

(N/A)	PROCESS SENSITIVE DIMENSION
DIMENSIONS ENCLOSED IN () INDICATE REFERENCE DIMENSIONS AND NO TOLERANCE LIMITS ARE ESTABLISHED	
FROM	CHART D
TO	> 12
TOLERANCE UNLESS OTHERWISE SPECIFIED	
+0.1	+0.2
ANGULAR TOLERANCE ±2°	

LINE DRAWN THROUGH A PART NUMBER INDICATES THAT PHYSICAL PARTS ARE NOT AVAILABLE FOR ORDERING.

PART NUMBERS THAT DO NOT HAVE A LINE PRESENT INDICATE THAT PHYSICAL PARTS ARE AVAILABLE FOR ORDERING.

CONTACT APTIV SALES TO ASSURE AVAILABILITY OF PARTS.

DWG TYPE: CUSTOMER PART DRAWING

STYLE: D

VOLUME (CM³):

DISTR CODE: D

UNLESS OTHERWISE SPECIFIED THIS DOCUMENT IS IN ACCORDANCE WITH ASME Y14.5M-1994 AS AMENDED BY THE GM GLOBAL DIMENSIONING AND TOLERANCING ADDENDUM-2001. SEPARATE PATTERNS OF FEATURES MAY BE GAGED SEPARATELY REGARDLESS OF DATUM REFERENCES.

ALL DIMENSIONS ARE IN MILLIMETERS

REFERENCE: 33376479-CDE01-S04

THIRD ANGLE PROJECTION

DO NOT SCALE

USE MATH DATA

• APTIV •

CONNECTION SYSTEMS

Anting, China

COPYRIGHT 2019 APTIV. ALL RIGHTS RESERVED.

THIS DRAWING IS THE PROPERTY OF APTIV AND CONTAINS APTIV CONFIDENTIAL INFORMATION. THE REPRODUCTION, DISTRIBUTION AND UTILIZATION OF THIS DOCUMENT OR ITS RELATED CAD MATH DATA, AS WELL AS COMMUNICATION OF ANY CONTENT TO OTHERS, WITHOUT EXPRESS AUTHORIZATION, IS PROHIBITED.

DR	DATE
APVD1 LINK GAO	16JL19
APVD2 ANYANG ZHANG	16JL19
APVD3 TIMON YU	16JL19
APVD4	
APVD5	

SUBSTANCES OF CONCERN AND RECYCLED CONTENT PER APTIV 10949001

MATERIAL SUGGESTED: AL 6082

DRAWING NAME: TAXI KIT

DRAWING NUMBER: 35219981

SIZE	SCALE	FRAME NO	SHEET NO	STG	REV	N/P
A1	2:1	1 OF 1	1 OF 1	R	01	-